

- NOTES:
1. CONSTRUCTION JOINTS ARE OPTIONAL WHERE SHOWN. KEY DIMENSIONS ARE 3/4 IN BY 2-3/8 INCHES.
 2. CLEARANCE SHALL BE 1-1/2 IN. FOR REINFORCING STEEL.
 3. THE TWO GRATE FRAMES SHALL BE CLAMPED TO THE "S" BEAM DURING CONCRETE PLACEMENT.
 4. CONSTRUCTION JOINTS ARE ALLOWED WHERE THE TOP PORTION OF THE INLET IS TO BE CONSTRUCTED MONOLITHICALLY WITH CURB AND SIDEWALK. THE CONSTRUCTION JOINT SHALL BE LOCATED AT PAVEMENT SUBGRADE. VERTICAL REINFORCEMENT SHALL EXTEND 6 IN. ABOVE THE CONSTRUCTION JOINT.
 5. WEEPHOLE DEPTH SHALL BE 14 IN. BELOW THE GRATE AND MAY VARY WITH ROAD SECTION.
 6. STEPS SHALL BE STEEL REINFORCED POLYPROPYLENE PLASTIC AND SHALL BE IN ACCORDANCE WITH CAL OSHA.
 7. ALL INLETS SHALL HAVE AN "ANTI-POLLUTION" THERMOPLASTIC DECAL APPLIED AS DIRECTED BY THE PUBLIC WORKS INSPECTOR.

No	By	Revision	<p align="center">CITY OF SAN PABLO</p> <p align="center">ONE ALVARADO SQUARE, SAN PABLO, CA 94806</p> <p align="center">(510) 215-3030 FAX 215-3031</p>				
Checked By: _____			<p align="center">TYPE B INLET SECTION AND NOTES</p> <p align="right">NO SCALE</p>		<p align="center">STD DET SD-04</p> <p align="center">SHEET 2 OF 3</p>		
Approved By: _____							
PUBLIC WORKS DIVISION MANAGER		DATE _____					

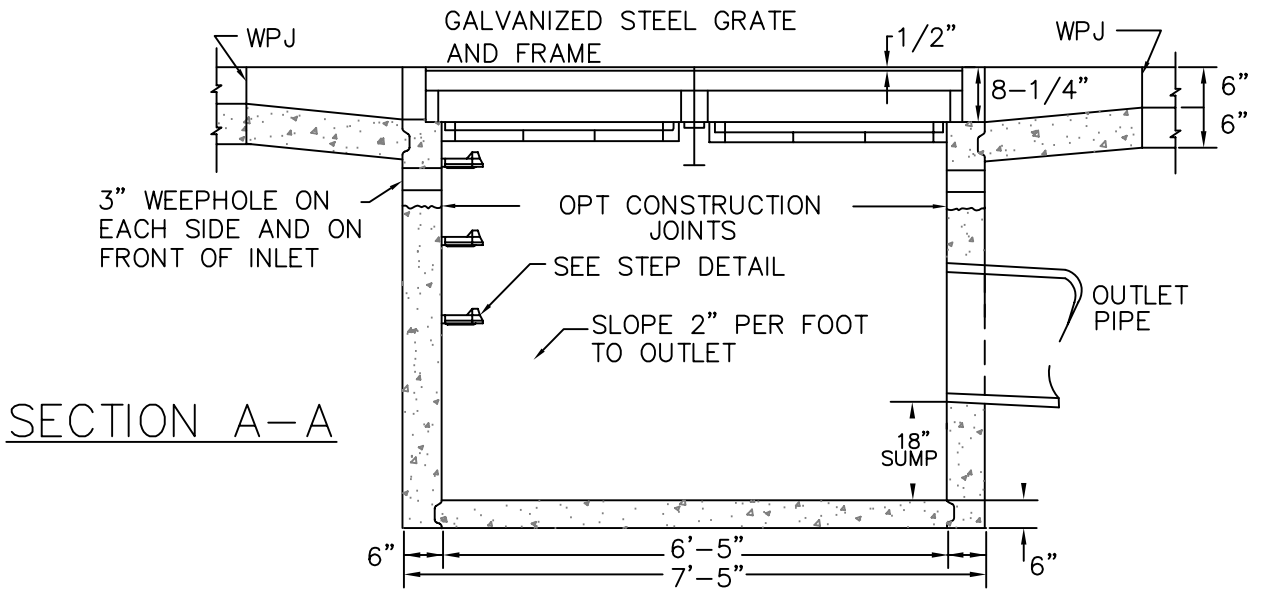

SECTION A-A

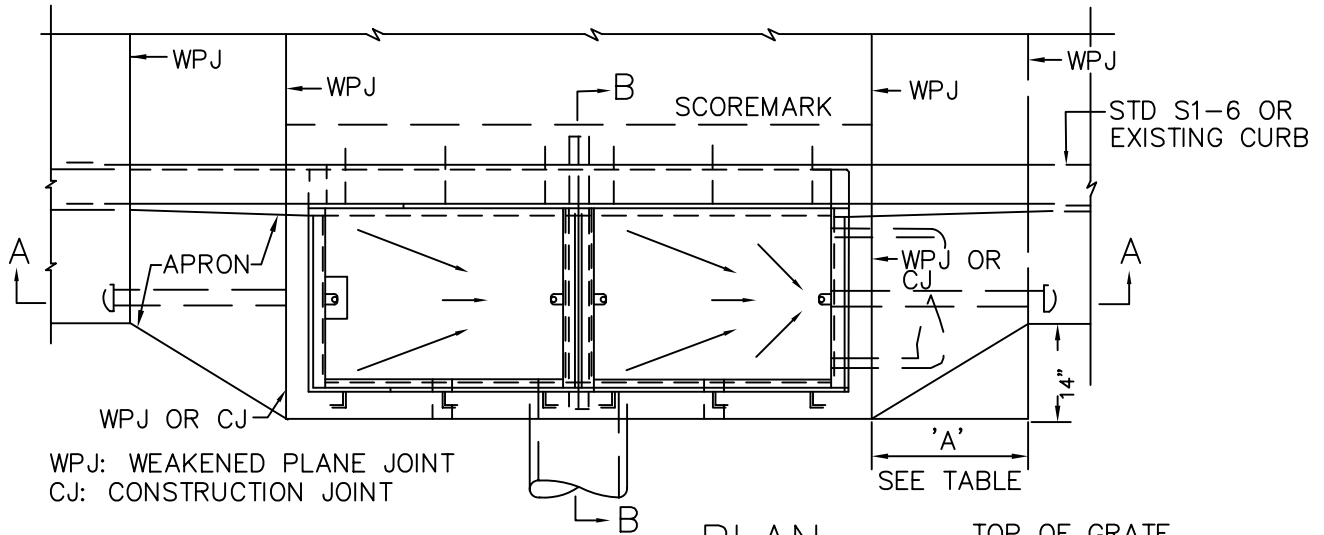

WPJ: WEAKENED PLANE JOINT
CJ: CONSTRUCTION JOINT

DIMENSION 'A' (INCHES)

UPSTREAM CURB GRADE	'A' UPSTREAM	'A' DOWNSTREAM
2% and less	24	24
3%	36	24
4%	48	24
5%	60	24
6%	72	24
7%	84	12
8%	96	12
9%	108	12
>10%	120	24

SEE 'DETAIL FOR STEEP CURB SLOPE' SHEET 2

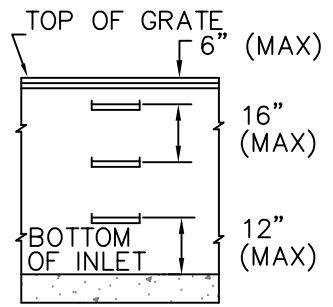

STEP DETAIL

No	By	Revision

CITY OF SAN PABLO

ONE ALVARADO SQUARE, SAN PABLO, CA 94806
(510) 215-3030 FAX 215-3031



Checked By: _____
Approved By: _____
PUBLIC WORKS DIVISION MANAGER DATE

TYPE B INLET
PLAN AND SECTION

NO SCALE

STD DET SD-04
SHEET 1 OF 3

DETAIL FOR SHEET 1

DIMENSION "A" (INCHES)

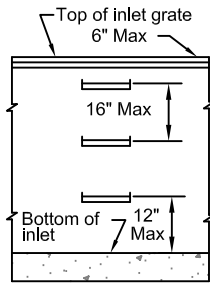

STEP DETAIL

UPSTREAM

CURB GRADE "A" UPSTREAM "A" DOWNSTREAM

2% and less	24	24
3%	36	24
4%	48	24
5%	60	24
6%	72	24
7%	84	12
8%	96	12
9%	108	12
10% and greater	120	24

SEE "DETAIL FOR
STEEP CURB"
BELOW

DETAIL FOR SHEET 2

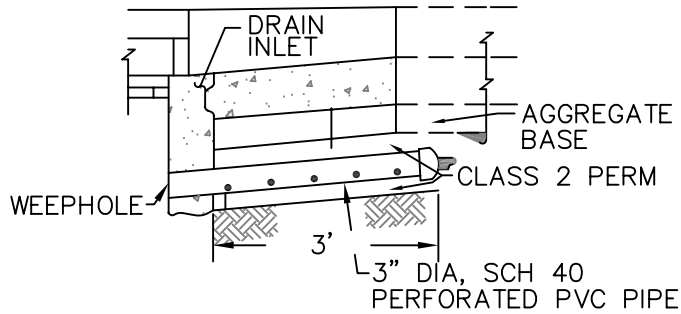

SIDE WEEPHOLE DETAIL

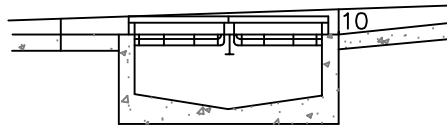

WHEN CURB GRADE UPSTREAM IS 5% OR GREATER
DEPRESS UPSTREAM EDGE OF GRATE FRAME TO 10 IN.

DETAIL FOR STEEP CURB SLOPE

No	By	Revision

CITY OF SAN PABLO

ONE ALVARADO SQUARE, SAN PABLO, CA 94806
(510) 215-3030 FAX 215-3031



Checked By: _____

Approved By: _____

PUBLIC WORKS DIVISION MANAGER _____ DATE _____

TYPE B INLET
TABLE AND STEP DETAIL

NO SCALE

STD DET SD-04

SHEET 3 OF 3